

**Name:** \_\_\_\_\_  
**Date:** \_\_\_\_\_  
**Track:** \_\_\_\_\_

### Track Conditions

Size:  Open  Med.  Tight  
 Traction:  High  Med.  Low  
 Surface:  Smooth  Med.  Bumpy

### Front Suspension

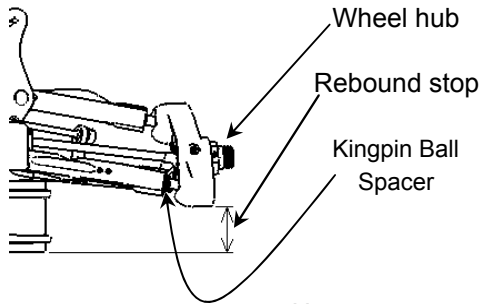

Kingpin ball spacer \_\_\_\_\_ mm  
 Camber angle \_\_\_\_\_ °  
 Upper arm spacer \_\_\_\_\_ mm  
 Toe angle \_\_\_\_\_ °  
 Rebound stop \_\_\_\_\_ mm  
 Anti-roll bar  $\varphi$  \_\_\_\_\_ mm  
 Wheel Hub \_\_\_\_\_ mm  
 Lower arm mount (Kick up)  0  1

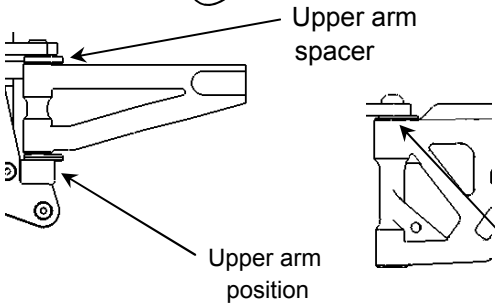

Lower arm plate (E0154A)    
 Upper arm position (E0148B, E0148C)     
 Lower arm spacer \_\_\_\_\_ mm

### Front Shocks

Piston \_\_\_\_\_  
 Oil # \_\_\_\_\_  
 Spring \_\_\_\_\_  
 Spring adjustment \_\_\_\_\_ mm  
 Shock position

### Steering Ackerman

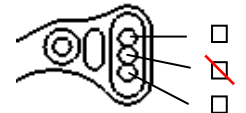

### Rear Suspension

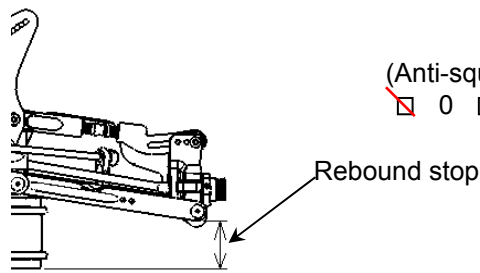

Camber angle \_\_\_\_\_ °  
 Lower arm mount \_\_\_\_\_ °  
 (Anti-squat)  0  1  
 (Toe angle) \_\_\_\_\_ °  
 Rebound stop \_\_\_\_\_ mm  
 Anti-roll bar  $\varphi$  \_\_\_\_\_ mm  
 Anti-squat (E0111C, E0111D)

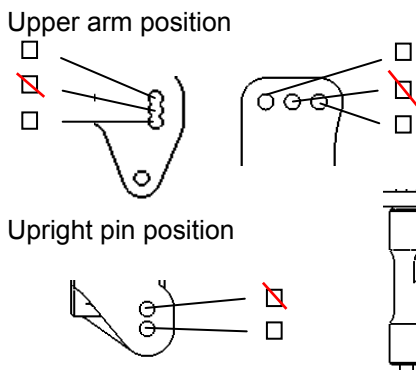

Upright  E0152  E0173 (Aluminium)  
 Wheelbase adjustment \_\_\_\_\_ mm  
 Lower arm spacer \_\_\_\_\_ mm

### Rear Shocks

Piston \_\_\_\_\_  
 Oil # \_\_\_\_\_  
 Spring \_\_\_\_\_  
 Spring adjustment \_\_\_\_\_ mm  
 Shock position

### Wing Position

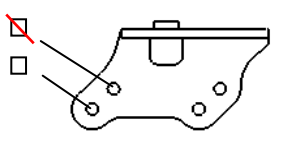

**Engine** Type \_\_\_\_\_  
 Gasket \_\_\_\_\_ mm Reducer  $\varphi$  \_\_\_\_\_  
 Plug \_\_\_\_\_ Fuel \_\_\_\_\_  
 Muffler \_\_\_\_\_

**Diff. Oil**  
 Front # \_\_\_\_\_ O-Ring \_\_\_\_\_ pcs.  Other \_\_\_\_\_  
 Center # \_\_\_\_\_ \_\_\_\_\_ pcs.  Other \_\_\_\_\_  
 Rear # \_\_\_\_\_ \_\_\_\_\_ pcs.  Other \_\_\_\_\_

**Tire**  
**Front** Type \_\_\_\_\_ Foam \_\_\_\_\_  
**Rear** Type \_\_\_\_\_ Foam \_\_\_\_\_

**Clutch** Clutch shoes  Aluminium \_\_\_\_\_  Other \_\_\_\_\_  
 Spring \_\_\_\_\_ mm  
 Clutch bell / Spur gear **T / T**

**Result**  
 Race time / Lap \_\_\_\_\_  
 Best lap (1Lap) \_\_\_\_\_

**Comments:**  
 \_\_\_\_\_  
 \_\_\_\_\_  
 \_\_\_\_\_  
 \_\_\_\_\_