

**Name:** \_\_\_\_\_  
**Date:** \_\_\_\_\_  
**Track:** \_\_\_\_\_

### Track Conditions

Size:	<input type="checkbox"/> Open	<input checked="" type="checkbox"/> Med.	<input type="checkbox"/> Tight
Traction:	<input type="checkbox"/> High	<input checked="" type="checkbox"/> Med.	<input checked="" type="checkbox"/> Low
Surface:	<input type="checkbox"/> Smooth	<input checked="" type="checkbox"/> Med.	<input checked="" type="checkbox"/> Bumpy

### Front Suspension

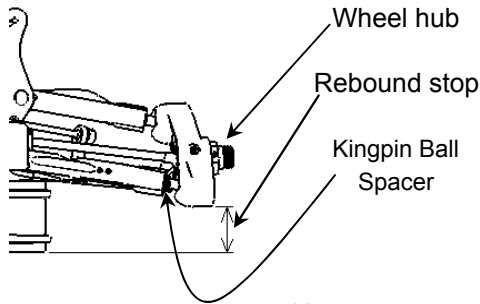

Kingpin ball spacer \_\_\_\_\_ mm  
 Camber angle \_\_\_\_\_ °  
 Upper arm spacer \_\_\_\_\_ mm  
 Toe angle \_\_\_\_\_ °  
 Rebound stop \_\_\_\_\_ mm  
 Anti-roll bar  $\varphi$  \_\_\_\_\_ mm  
 Wheel Hub \_\_\_\_\_ mm  
 Lower arm mount (Kick up)  0  1



Lower arm plate (E0154A)

Upper arm position (E0148B, E0148C)

Lower arm spacer \_\_\_\_\_ mm

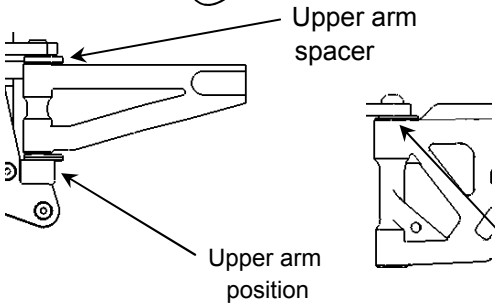

### Front Shocks

Piston \_\_\_\_\_  
 Oil # \_\_\_\_\_  
 Spring \_\_\_\_\_  
 Spring adjustment \_\_\_\_\_ mm  
 Shock position

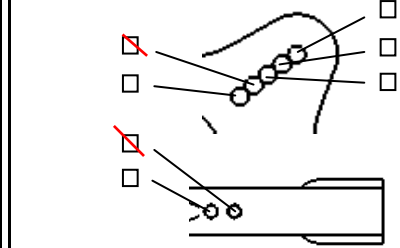

### Steering Ackerman

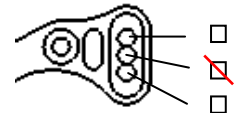

### Rear Suspension

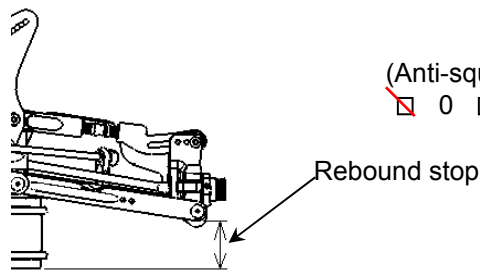

Camber angle \_\_\_\_\_ °  
 Lower arm mount \_\_\_\_\_ °  
 (Anti-squat)  0  1  
 (Toe angle) \_\_\_\_\_ °  
 Rebound stop \_\_\_\_\_ mm  
 Anti-roll bar  $\varphi$  \_\_\_\_\_ mm  
 Anti-squat (E0111C, E0111D)



Upright  E0152  E0173 (Aluminium)

Wheelbase adjustment \_\_\_\_\_ mm

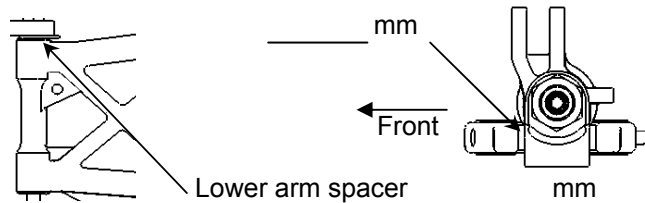
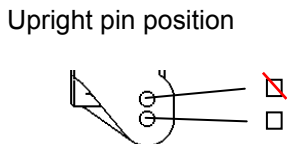
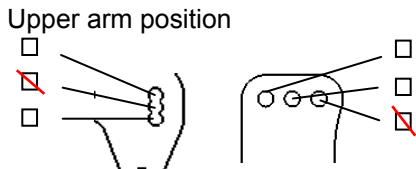

### Rear Shocks

Piston \_\_\_\_\_  
 Oil # \_\_\_\_\_  
 Spring \_\_\_\_\_  
 Spring adjustment \_\_\_\_\_ mm  
 Shock position

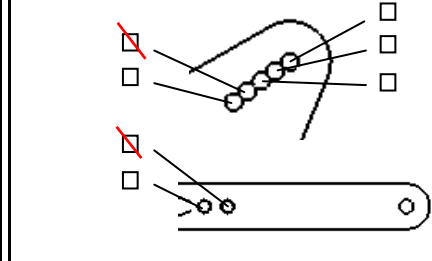

### Wing Position

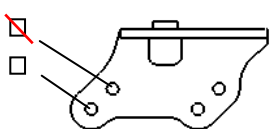

<b>Engine</b>	Type _____	Gasket _____ mm	Reducer $\varphi$ _____
	Plug _____	Fuel _____	
	Muffler _____		

<b>Diff. Oil</b>	Front # _____	O-Ring _____ pcs.	<input type="checkbox"/> Other _____
	Center # _____	_____ pcs.	<input type="checkbox"/> Other _____
	Rear # _____	_____ pcs.	<input type="checkbox"/> Other _____

<b>Tire</b>	<b>Front</b>	<b>Rear</b>
	Type _____	Type _____
	Foam _____	Foam _____

<b>Clutch</b>	Clutch shoes <input type="checkbox"/> Aluminium _____
	<input checked="" type="checkbox"/> Other _____
	Spring _____ mm
	Clutch bell / Spur gear <b>T / T</b>

**Result**  
 Race time / Lap \_\_\_\_\_  
 Best lap (1Lap) \_\_\_\_\_

**Comments:**  
 \_\_\_\_\_  
 \_\_\_\_\_  
 \_\_\_\_\_  
 \_\_\_\_\_